

Passive Wearable Electrostatic Tags

by

Babak Nivi

Bachelor of Science in Electrical Engineering and Computer Science, Massachusetts
Institute of Technology (1997)

Submitted to the Department of Electrical Engineering and Computer Science
in partial fulfillment of the requirements for the degree of

Master of Engineering in Electrical Engineering and Computer Science

at the

MASSACHUSETTS INSTITUTE OF TECHNOLOGY

September 1997

© Massachusetts Institute of Technology 1997. All rights reserved.

Author
Department of Electrical Engineering and Computer Science
August 19th, 1997

Certified by
Neil A. Gershenfeld
Associate Professor of Media Arts and Sciences
Thesis Supervisor

Accepted by
Arthur C. Smith
Chairman, Departmental Committee on Graduate Theses

Passive Wearable Electrostatic Tags

by

Babak Nivi

Submitted to the Department of Electrical Engineering and Computer Science
on August 19th, 1997, in partial fulfillment of the
requirements for the degree of
Master of Engineering in Electrical Engineering and Computer Science

Abstract

Current methods for wireless power transmission include magnetic flux coupling, microwaves, radio-frequency waves, and optics. This thesis presents a novel method to transmit data and power wirelessly *through* the human body. We model the body as a conductor (our insides) surrounded by an insulator (our skin). Therefore, power and data can be electrostatically coupled to the body and sent through it.

We apply this technology to a new type of Radio Frequency Identification (RFID) tag that I call the *bodytag*. The bodytag is a passive wearable electrostatic tag: it contains no battery, can be worn on the human body, and receives power and communicates electrostatically through the body. The bodytag is interrogated when the user brings his hand near a reader. The bodytag is much cheaper than conventional magnetostatic RFID tags because it contains no magnetic flux coupling coil.

We present two types of bodytags. The *loading mode* tag transmits data to the reader by modulating its own impedance. The *transmit mode* tag transmits data by applying an electrostatic signal to the body.

Thesis Supervisor: Neil A. Gershenfeld

Title: Associate Professor of Media Arts and Sciences

Passive Wearable Electrostatic Tags

by

Babak Nivi

Submitted to the Department of Electrical Engineering and Computer Science
on August 19th, 1997, in partial fulfillment of the
requirements for the degree of
Master of Engineering in Electrical Engineering and Computer Science

Abstract

Current methods for wireless power transmission include magnetic flux coupling, microwaves, radio-frequency waves, and optics. This thesis presents a novel method to transmit data and power wirelessly *through* the human body. We model the body as a conductor (our insides) surrounded by an insulator (our skin). Therefore, power and data can be electrostatically coupled to the body and sent through it.

We apply this technology to a new type of Radio Frequency Identification (RFID) tag that I call the *bodytag*. The bodytag is a passive wearable electrostatic tag: it contains no battery, can be worn on the human body, and receives power and communicates electrostatically through the body. The bodytag is interrogated when the user brings his hand near a reader. The bodytag is much cheaper than conventional magnetostatic RFID tags because it contains no magnetic flux coupling coil.

We present two types of bodytags. The *loading mode* tag transmits data to the reader by modulating its own impedance. The *transmit mode* tag transmits data by applying an electrostatic signal to the body.

Thesis Supervisor: Neil A. Gershenfeld
Title: Associate Professor of Media Arts and Sciences

Acknowledgments

This work was conducted in the Physics and Media group of the MIT Media Lab under the supervision of Professor Neil Gershenfeld. I would like to thank Professor Gershenfeld for the opportunity to conduct this research and learn so much. I would also like to thank the entire Physics and Media group for their assistance in this research.

This work was funded in part by a Graduate Research Fellowship from the National Science Foundation and the Things That Think Consortium at the MIT Media Lab.

Contents

1	Introduction	7
1.1	Wireless Intra-body Power and Data Transmission	8
1.1.1	Motivation for Intra-Body Power and Data Transmission	8
1.1.2	How to Transmit Power and Data Through the Body	8
1.1.3	PAN	10
1.1.4	Potential Applications	11
1.2	RFID	11
1.2.1	The State of the Art in RFID	12
1.2.2	RFID vs. Barcodes	12
1.2.3	The Bodytag	13
1.3	Thesis Outline	13
2	An Electrostatic Model of the Tag, Body, and Reader	15
2.1	Electrostatic Properties of the Human Body	15
2.2	The Model	15
2.3	Why the Tag is in Nicky’s Shoe and Breaking Symmetry	16
2.4	Conservative Calculation of the Power Available to the Bodytag	17
3	Loading Mode	21
3.1	What is Loading Mode?	21
3.2	How do we Receive Data from the Tag?	21
3.3	Implementation of the Loading Mode Tag and Reader	25
3.3.1	The Loading Mode Tag	25
3.3.2	The Loading Mode Reader	26
3.4	The Doorknob Demo	27
3.5	Methods to Push the Performance of the Loading Mode Reader	28
3.6	Some Comments on Loading	30

4	Transmit Mode	31
4.1	The Transmit Mode Bodytag	31
4.2	The Transmit Mode Reader	32
5	Conclusions and Future Work	33
5.1	Health Concerns	33
5.2	Thoughts on How to Move the Tag out of the Shoe and into the Back Pocket	34
5.3	Final Comments	34
A	Matlab Code for Power Calculations	36
A.1	R Dependence	36
A.2	f_r Dependence	38
B	Implementation of the Loading Mode Reader	42
B.1	Loading Mode Reader Schematic	42
B.2	Oscillator Code	44
B.3	Microcontroller Code	46

List of Figures

1-1	A tag and reader exchange data and power through Nicky's body.	9
1-2	Equivalent circuit diagram of Nicky's interaction with the tag and reader.	10
2-1	The electrostatic model of the reader, body, and tag interaction.	16
2-2	Parasitic capacitances between the tag, body, and ground.	17
2-3	The bodytag.	18
2-4	Voltage, Current, and Power across the tag electrodes vs. tag resistance for $f_r = 125$ kHz	19
2-5	Voltage, Current, and Power across the tag electrodes vs. reader frequency for $R = 50$ k Ω	20
3-1	Loading mode tag with Q -switching data transmission.	22
3-2	Magnitude and Phase of Z_{th} as a function of R with $f_r = 125$ kHz.	22
3-3	Magnitude and Phase of Z_{th} as a function of f_r with $R = 50$ k Ω	23
3-4	The LC-tank used to detect the bits coming from the tag ($V_{C_{th}} = V_C$).	24
3-5	Block diagram of the loading mode reader.	26
3-6	Using a varactor to control the resonant frequency of the tank ($V_{C_{th}} = V_C$)	29
3-7	Block diagram of the loading mode crystal-based bodytag.	30
4-1	Block diagram of the transmit mode bodytag.	32
B-1	Loading mode reader schematic.	43

Chapter 1

Introduction

In this thesis, I describe how data and power can be wirelessly (and safely) transmitted *through* the human body. We can send power and data through the body by capacitively coupling displacement current into the body and using the earth ground provided by our environment as the current return path. Within this general context, I present an application of this novel type of transmission to a new type of Radio Frequency Identification (RFID) tag that we will call the *bodytag*. The bodytag is a *passive wearable electrostatic tag*: it has no batteries; it is a wearable credit-card sized device that can compute as well as store, transmit, and receive information; and it receives power and communicates electrostatically through the body.

Thomas Zimmerman and Neil Gershenfeld discovered that analog and digital signals can be sent through the human body [1, 2]. In other words, devices close to the human body can use the body as a data bus. Since all signals contain energy, Zimmerman and Gershenfeld also inadvertently discovered a method to transmit power through the body. However, they did not realize that useful amounts of power could be safely transmitted through the body.

In 1996, E. Rehmi Post, a graduate student in the Physics and Media group of the MIT Media Lab, demonstrated the first device that could be powered through the body. Using a simple antenna (two electrodes and an inductor), Post wirelessly powered an LED. He demonstrated that the body can be safely used as a bus for power transmission [3].

This thesis will focus on the application of *intra-body power* and *intra-body data* to create a passive wearable electrostatic tag: the bodytag.¹ I will comment on other applications of the technology presented here in Section 1.1.4 but I will let RFID applications focus this thesis. In Section 1.1 I will begin to describe how intra-body power and data work and in Section 1.2 I will describe the application of the bodytag to RFID.

¹I will often use the term *intra-body data* as a short form for data transmission through the body. Likewise with *intra-body power*.

1.1 Wireless Intra-body Power and Data Transmission

Zimmerman developed the first intra-body communication system [1] and Gray modeled the system and its channel capacity [4]. I will let their theses be the primary source of information on intra-body data. However, I will briefly review their work and show how intra-body data and intra-body power are really the same thing.

1.1.1 Motivation for Intra-Body Power and Data Transmission

Zimmerman coined the term *Personal Area Network (PAN)* to describe a network of devices that communicate by intra-body data. He describes the motivation for PAN well:

As electronic devices become smaller, lower power, and less expensive, we have begun to adorn ourselves with personal information and communication appliances. These devices include cellular phones, personal digital assistants (PDAs), pocket video games, pen based computer pads, palm top computers, and pagers. Currently, there is no standard method to interconnect these personal electronic devices. The personal area network is a means to interconnect these personal devices, in a manner appropriate to the power, size, and cost of these devices.

...

A person who carries a watch, pager, cellular phone, cassette/fm player/recorder, PDA, and notebook computer is carrying five displays, three keyboards, two speakers, two microphones, and three communication devices. The duplicity of input/output (I/O) devices is a result of the inability of the devices to exchange data. All of these devices contain some logical processing unit, typically a microprocessor. With proper networking structure these devices can share computational resources, either performing distributed computation or relying on neighbors with more specialized and higher capacity processing power to perform functions too intensive for the resident processor. The ability to share resources is tempered by inter-communication channel capacity and system complexity. [1, pages 8–9]

PAN devices do not transmit a significant amount of power into the far-field. Therefore, PAN also partially circumvents channel sharing and eavesdropping issues. The communication channel is shared by Physical Division Multiple Access (PDMA): PAN devices do not interfere with each other if they are not near each other. The communication channel is shared physically in space.

So far, I have presented the motivation for intra-body data. The motivation for intra-body power is simple: in certain situations, we do not want our PAN devices to be battery powered.

1.1.2 How to Transmit Power and Data Through the Body

In this section, I will begin to describe how we can transmit power and data through the body. In Chapter 2, I will present the full model of this phenomenon; in this section I will present a qualitative model. Zimmerman has also presented a model of this phenomenon [1].

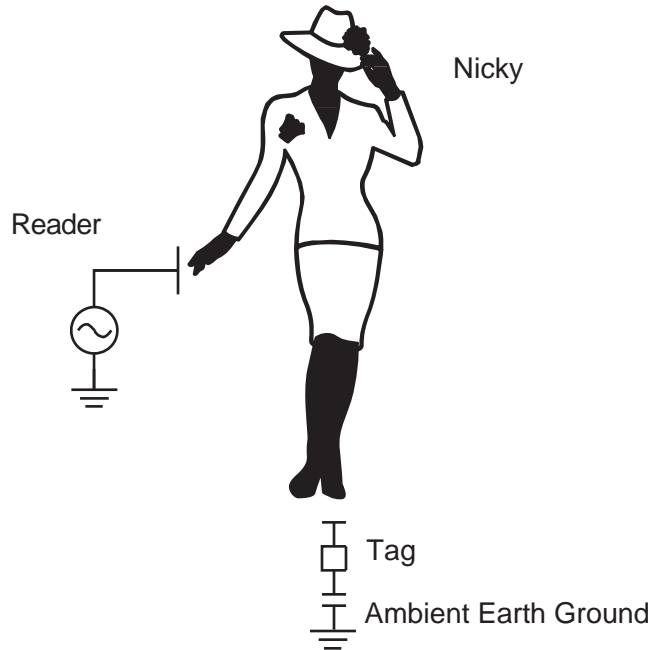

Figure 1-1: A tag and reader exchange data and power through Nicky's body.

We can transmit power and data through the body by capacitively coupling displacement current into the body and using the earth ground provided by our environment as the current return path. Henceforth, I will use the term *ambient earth ground* to describe the earth ground provided by our surroundings (the floor, pipes, chairs, tables, etc.).

Figure 1-1 schematically depicts intra-body power and data transmission.² For the purposes of this thesis, we will model the human body as a solid piece of ideal conductor (our insides) surrounded by an ideal insulator (our skin). We cannot send DC current through the body because it is surrounded by an insulator—not to mention that this would be tremendously dangerous. But recall that we are modeling our insides as a perfect conductor. *We can send AC current through the body by capacitively coupling to this conductor and using this conductor as a single electrode in a network of capacitors.* Though no charge enters or leaves the body—charge only moves around inside the body—this has the same effect as a real current moving through the body. In Figure 1-1, Nicky couples displacement current into her body by bringing her hand near the reader electrode.

Now that current has entered her body, the only other thing we need to complete the circuit is a place for the current to go. *We use ambient earth ground as a return path for the AC current.* In Figure 1-1, Nicky's foot is capacitively coupled to the tag and the tag is capacitively coupled to earth ground, giving the displacement current a return path to ground.

²The figure contains two devices labelled tag and reader. I have not defined these terms yet but they are not relevant to the current discussion.

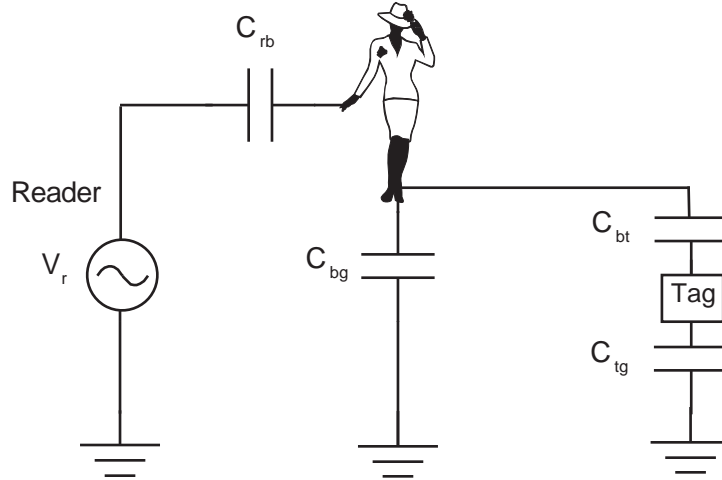

Figure 1-2: Equivalent circuit diagram of Nicky's interaction with the tag and reader.

AC current enters the body as displacement current at the reader and leaves the body as displacement current to the tag. The current returns to ground by leaving the tag as displacement current and returning to earth ground. Figure 1-2 shows a circuit diagram of Nicky's interaction with the tag and reader. The capacitance from the reader to Nicky is represented by C_{rb} , Nicky's capacitance to ground is represented by C_{bg} , Nicky's capacitance to the top tag electrode is represented by C_{bt} , and the capacitance of the tag's bottom electrode to ground is represented by C_{tg} .

Now that we know how to send AC current through the body, we know how to send power and data through the body. In Figure 1-1, the reader sends power and data to the tag by sending AC current through Nicky's body to the tag. The tag is a passive device; it has no power source of its own. The tag uses the AC current passed through the body as a power source. The tag can send data to the reader by applying another AC current to Nicky's body or by using another method that I will describe in Section 3.

Why is the human body involved in the signalling between the tag and the reader? Without the body between the tag and reader, the capacitance between the tag and the reader is miniscule unless the tag and reader are within centimeters of each other. With the body between the tag and reader, there is a much higher capacitance (lower impedance) between the tag and the reader even at distances of a few meters.

1.1.3 PAN

Zimmerman presented a *handshake demonstration* as an application of the PAN technology that he developed [1]. A PAN transmitter is placed under Nicky's foot and a PAN receiver is placed under Micky's foot. When Nicky and Micky shake hands, they complete the circuit formed by the

PAN transmitter and receiver. The PAN transmitter under Nicky's foot can then transmit Nicky's business card through her body and down through Micky's body to the PAN receiver under Micky's foot.

Though the PAN transmitter and receiver were not embedded in the user's shoes, Zimmerman argued that they could easily be embedded there. Both the PAN transmitter and receiver were battery powered in the handshake demo.

Zimmerman's PAN transmitter and receiver communicated at 2400 baud using On-Off Keying (OOK). Post and Matthew Reynolds have developed the PAN III *transceiver* that uses Frequency Shift Keying (FSK) at 2400 baud [3].

1.1.4 Potential Applications

Abstractly, PAN is most useful when the desire to close a logical switch is correlated with the physical gesture of touch. For example, in the handshake demo, the handshake closed the logical switch for the users to exchange business cards. In another example, a door might automatically unlock for an authorized user when he touches a doorknob. In this case, the doorknob would communicate with a PAN transceiver on the user's body. In another example, a customer at a supermarket might pay for his groceries simply by touching his finger to an electrode at the checkout. In this case, the electrode would conduct the transaction with a PAN transceiver on the user's body.

As I will discuss in Section 2, the ideal electric location for a PAN transceiver is in the user's shoe. However, the ultimate goal is to be able to embed PAN transceivers anywhere on the user's body: in credit cards, wallets, watches, etc.

1.2 RFID

RFID is the name of a method for *tagging* objects. Abstractly, a *tag* is a device placed on an object that lets us determine the object's identity by using a *reader*. For example, a barcode is a tag placed on boxes. A bar code scanner is the reader that lets us determine whether the box contains a television, chocolate bar, or cereal. Barcodes are read-only devices that cannot be updated with new information without physically replacing the barcode. The reader reads the tag optically and therefore needs line-of-sight access to the tag. A bar code scanner can typically read a bar code from a distance of a few centimeters. I will use the term *read range* to describe the maximum distance at which a reader can read a tag.

1.2.1 The State of the Art in RFID

In RFID, the tag is a small, low power microchip combined with an antenna that harvests electrostatic, magnetostatic, or microwave power and communicates with the reader.³ Though some RFID tags contain batteries, all tags that I will discuss in this thesis are passive: they are powered remotely. The dimensions of the chip are typically 5 mm x 5 mm x 1 mm and the power consumption of the chip is typically a few microwatts. An electrostatic tag antenna is a pair of planar electrodes with typical surface areas of 25 cm² each. A magnetostatic tag antenna is a coil typically with 100–1000 turns and a 1–5 cm radius.

The reader is another antenna attached to the appropriate electronics. An electrostatic reader antenna is a pair of planar electrodes with a typical surface area of 1000 cm² each. A magnetostatic reader antenna is a coil with 100–1000 turns and a typical radius of 20 cm. The reader is responsible for powering the tag and communicating with the tag. The microwave tag and reader are not relevant to this thesis. For more information on various tagging technologies including RFID, see Richard Fletcher Master's thesis [5].

Currently, there are no commercial electrostatic RFID systems available. I will briefly present the operation of a magnetostatic RFID system (the electrostatic system is analogous). A fixed frequency AC current (≈ 500 mA) through the reader coil induces a quasi-magnetostatic field near the reader coil. Typical field frequencies are 125 kHz, 3.25 MHz, and 13.56 MHz. As I discussed above, the tag consists of a coil attached to the pins of a two pin microwatt processor. When the tag is brought near the reader, the AC magnetic field created by the reader induces an AC magnetic flux through the tag coil. This AC magnetic flux produces a voltage at the terminals of the tag coil. This voltage is used to power the chip on the tag. The chip then transmits a multi-bit identification to the reader that uniquely identifies the tag. I will discuss the transmission method in 1.3.

1.2.2 RFID vs. Barcodes

A magnetostatic RFID system has many advantages over barcodes:

- The chip can store and transmit thousands of bits of information.
- The read range of a magnetostatic system is typically 10–50 cm.
- The reader can read the tag through any material that does not shield magnetic fields at the reader's operating frequency. Therefore, the reader does not need line-of-sight access to the tag.
- If the chip has a memory, such as an EEPROM, the information in the tag can be modified by the reader.

³In this thesis electrostatic and magnetostatic mean quasi-electrostatic and quasi-magnetostatic respectively.

The main disadvantage of RFID is the cost of the tag. Barcodes cost literally nothing to manufacture. The typical cost of a magnetostatic RFID tag is \$0.50 in quantity. It is economically infeasible to tag every item in a grocery store with an RFID tag. However, a significant portion of the cost in a magnetostatic RFID tag is the cost of the coil attached to the chip and other manufacturing processes associated with the coil. The chip can cost as little as \$0.20 whereas the coil itself can cost \$0.10. The bodytag replaces that coil with a pair of electrodes and an inductor, reducing the cost of the tag tremendously.

RFID systems are typically used in access control, inventory tracking, and animal tagging. Hereafter, any reference to tags will denote an RFID tag.

1.2.3 The Bodytag

In this thesis, I describe a passive wearable electrostatic tag, the bodytag, in the context of RFID. The tag consists of electronics, two electrodes, and an inductor embedded into the user's shoe. Refer back to Figure 1-1 to see how this RFID system operates. Nicky has a tag in her shoe. When she brings her hand or another body part near the reader, the reader sends power through her body to power the electronics in the tag. The tag then sends the appropriate data through Nicky's body to the reader. Of course, the reader is much more than just a function generator though it is schematically represented as a function generator in Figure 1-1.

The tag is small (5 cm x 5 cm x 1 cm) and lightweight (a few grams) and is thus wearable. The tag contains no power source; it is electrostatically powered through the body. The tag contains a low power microprocessor with an EEPROM: it can electrostatically transmit the user's identity, credit card number, bank account balance, etc. to the reader. Though I am focusing on RFID applications, the reader is invited to dream up other applications for this technology.

As I stated above, we are modeling the human body as a perfect conductor surrounded by an insulator. Therefore the human body can screen and guide electrostatic fields. The human body does not screen or guide magnetostatic fields at low frequencies. An electrostatic bodytag is possible only because the human body can screen and guide electrostatic fields.

1.3 Thesis Outline

An elaboration of the model of the interaction between the reader, body, and the tag is presented in Chapter 2.

This thesis describes two embodiments of the bodytag. Most commercial magnetostatic RFID tags send data to the reader by modulating the impedance they present to the reader. I will call this method of data transmission *loading mode*. The loading mode bodytag is presented in Chapter 3. Very few commercial magnetostatic RFID tags send data to the reader by applying a signal to the

tag coil. I will call this method of data transmission *transmit mode*. The transmit mode bodytag is presented in Chapter 4.

Finally, conclusions and opportunities for future work in this area will be discussed in Chapter 5.

Chapter 2

An Electrostatic Model of the Tag, Body, and Reader

In this chapter, we will explore the model presented in Section 1.1.2. I will also present a conservative calculation of the power available to the tag in the geometries of interest in this thesis.

The readers described in Chapters 3 and 4 both operate at fixed frequencies below 1 MHz and use single electrodes (monopoles) as antennas. The wavelength of a 1 MHz uniform plane wave in free space is approximately 300 m. Therefore, all models and calculations presented in this thesis assume that the tag and reader are operating in the *electrostatic limit*. Specifically, we use a lumped circuit elements in all of our models.

2.1 Electrostatic Properties of the Human Body

We model the human body as a perfect conductor (our insides) surrounded by an insulator (skin). Of course, skin is not a perfect insulator but we can easily achieve this effect. We simply coat the reader and tag electrodes with an insulator. Though our insides are not a perfect conductor, our models ignore our internal resistance because it is negligible compared to the other circuit impedances presented in Section 2.2. Zimmerman’s rough calculation of our internal resistance yielded 251Ω [1].

2.2 The Model

Figure 1-2 illustrates the model that we will use throughout the thesis. An equivalent circuit is shown in Figure 2-1. Now that we have modeled the human body as a conductor surrounded by a perfect insulator, Figure 2-1 should be clear. The reader capacitively couples to Nicky’s hand (C_{rb}), Nicky’s foot capacitively couples to the tag (C_{bt}), and the tag capacitively couples to ambient

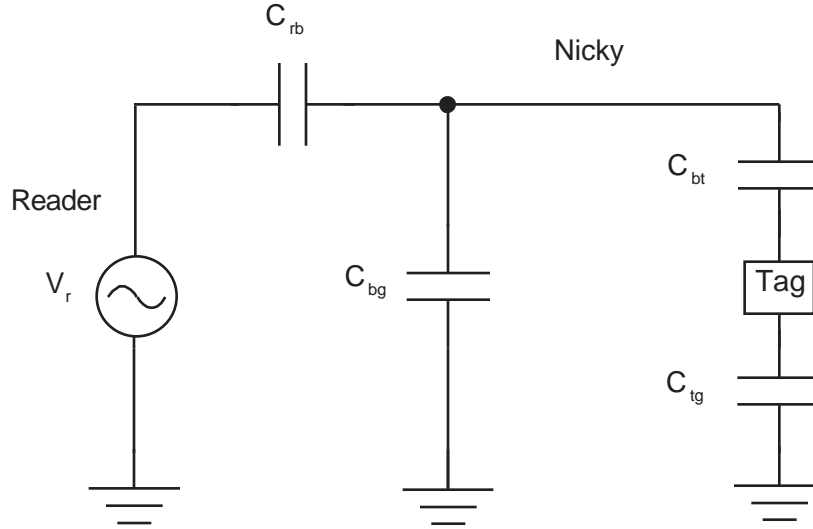

Figure 2-1: The electrostatic model of the reader, body, and tag interaction.

earth ground to complete the circuit (C_{tg}). Nicky also capacitively couples to ambient earth ground, resulting in C_{bg} . 100 pF is a good rough approximation to all of the capacitances. In both the transmit mode and loading mode readers, $V_r = V_0 e^{j\omega_r t}$ where $\omega_r = 2\pi f_r$ and $V_0 \approx 50$ V.

Since the impedance of a capacitor is $1/j\omega C$, it would seem that the reader should operate at the highest practical frequency to reduce the impedance of the current path from the tag to the reader. This is not correct. Even assuming that this electrostatic model is valid at all reader frequencies (this is certainly false), C_{bg} sets a fundamental limit on the current available at the tag for a fixed reader voltage V_r . As ω goes up, C_{bg} shunts more current to ground. Choosing ω is a game of trade-offs that I will not address. However, choosing ω correctly can optimize the power available to the tag.

2.3 Why the Tag is in Nicky's Shoe and Breaking Symmetry

Various parasitic capacitances are not included in Figure 2-1. For now, we are assuming that these are negligible. The most deleterious parasitic capacitances are illustrated in Figure 2-2. The parasitics are the capacitance from the top electrode of the tag to ground (C_{p1}) and the capacitance of the bottom electrode of the tag to the body (C_{p2}).

Zimmerman explained the effects of these parasitics [1, 2]. If $C_{bt} \approx C_{p1}$ and $C_{tg} \approx C_{p2}$, the tag sees no current, voltage, or power. C_{bt} , C_{tg} , C_{p1} , and C_{p2} can be drawn in a capacitive Wheatstone bridge about the tag to emphasize this point [1, 2]. We must break this symmetry to get power to the tag. This explains why the tag is in Nicky's shoe: in this geometry, the large value of C_{tg} breaks the symmetry [4]. I will present ideas on how to take the tag out of the shoe and put it in other

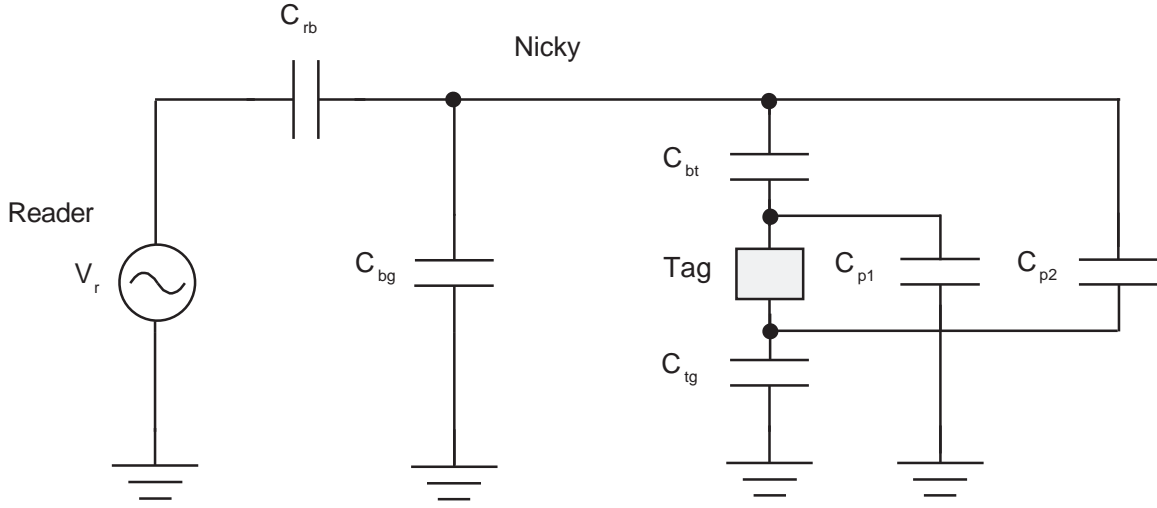

Figure 2-2: Parasitic capacitances between the tag, body, and ground.

places such as the user's back pocket in Section 5.2.

2.4 Conservative Calculation of the Power Available to the Bodytag

The Bodytag

In both the loading and transmit mode, the bodytag consists of two electrodes, a capacitor, an inductor, and other tag electronics as in Figure 2-3. The capacitor and inductor are chosen to be resonant at the reader frequency ω with the highest possible Q . The resonant frequency, ω , and Q of a parallel RLC network are

$$\omega = \frac{1}{\sqrt{LC}}$$

$$Q = R\sqrt{\frac{C}{L}}. \quad (2.1)$$

Though Equation 2.1 indicates that the largest possible C and smallest L give the highest Q , practical losses in the capacitor and inductor will mitigate the choice of C and L .

Power Calculation

We will ignore the power conversion efficiency of the tag electronics and make a conservative calculation of the power available at the tag. We will use the geometry shown in Figure 2-1 and the tag

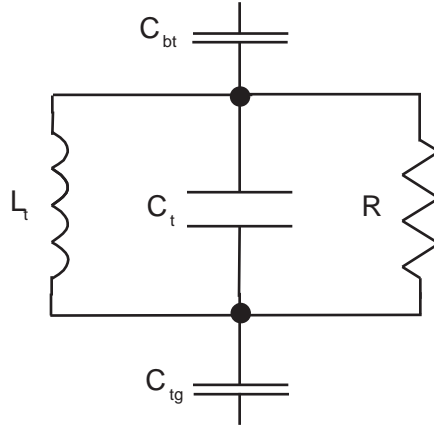

Figure 2-3: The bodytag.

Note that the tag electronics are modeled by a resistor, R .

shown in Figure 2-3. Though the tag electronics are non-linear, they consume an average current and we model the power dissipation of these electronics with the resistor R .

We will use the following conservative component values: $C_{rb} = C_{bt} = C_{tg} = 50$ pF and $C_{bg} = 200$ pF. To make the calculation conservative, I choose C_{rb} , C_{bt} , and C_{tg} smaller than they typically are and choose C_{bg} larger than it's typical value [1].

We set $V_r = 50e^{j2\pi f_r t}$ where and we set the tag component values so that the tag LC tank is resonant at 125 kHz: $L_t = 9.5$ mH and $C_t = 170$ pF. The values of L_t , C_t , and V_r are drawn from the values used in the loading mode bodytag and reader described in Section 3.

Using Matlab, we numerically solve the voltage across R , the current through R , and the power dissipated in R for various values of R with $f_r = 125$ kHz (Figure 2-4). We also solve for these parameters with $R = 50$ k Ω for various values of f_r (Figure 2-5). The Matlab code is included in Appendix A.

Since the tag is actually a non-linear device, these calculations are only a rough guide to the power available to the tag. The figures indicate that there is as much as 1.5 mW of power available to the tag. These calculations correlate well with lab observations. Figure 2-5 also indicates that the resonance of the system has been shifted down from 125 kHz to approximately 118 kHz by the capacitances outside of the tag.

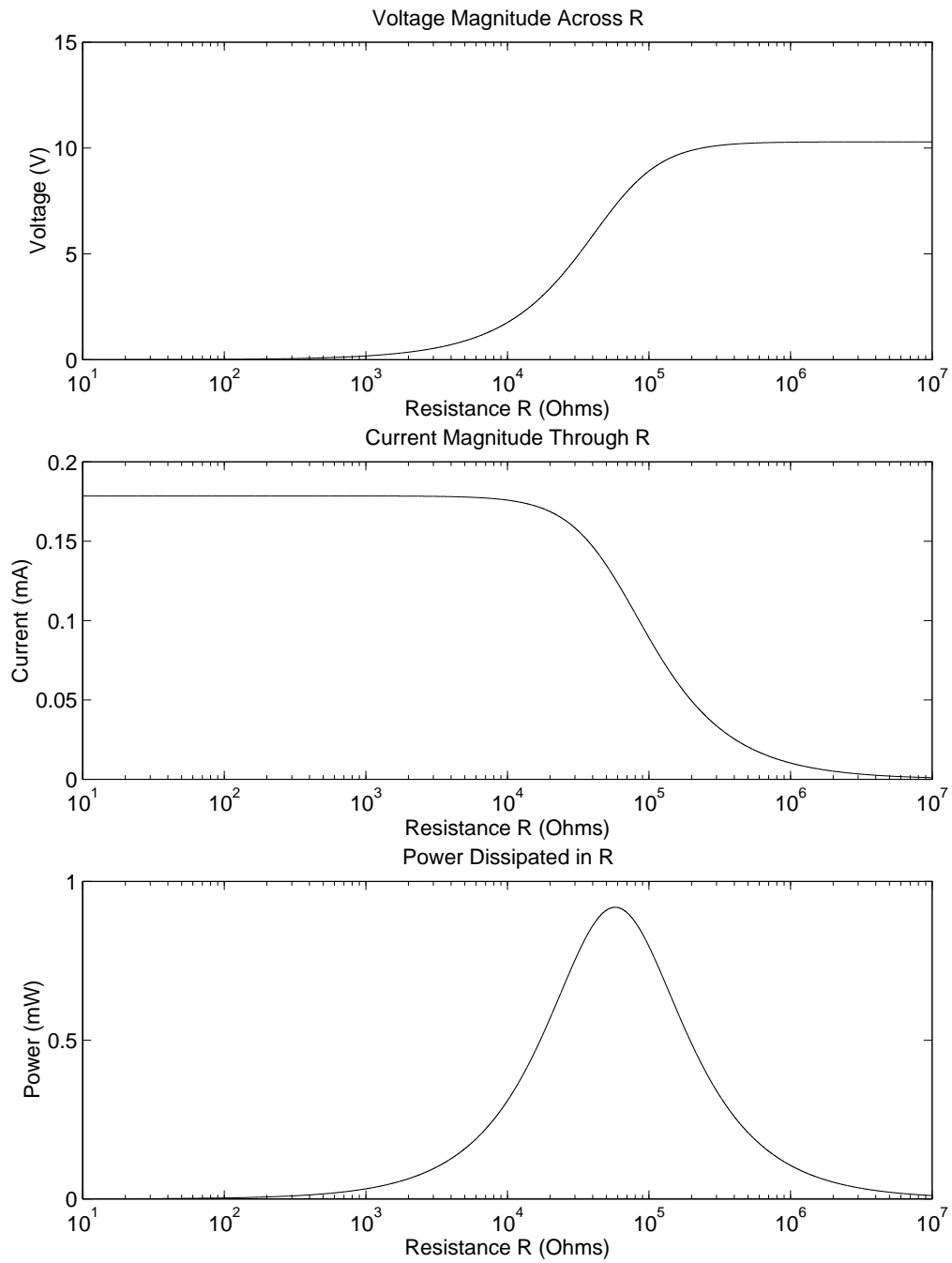

Figure 2-4: Voltage, Current, and Power across the tag electrodes vs. tag resistance for $f_r = 125$ kHz

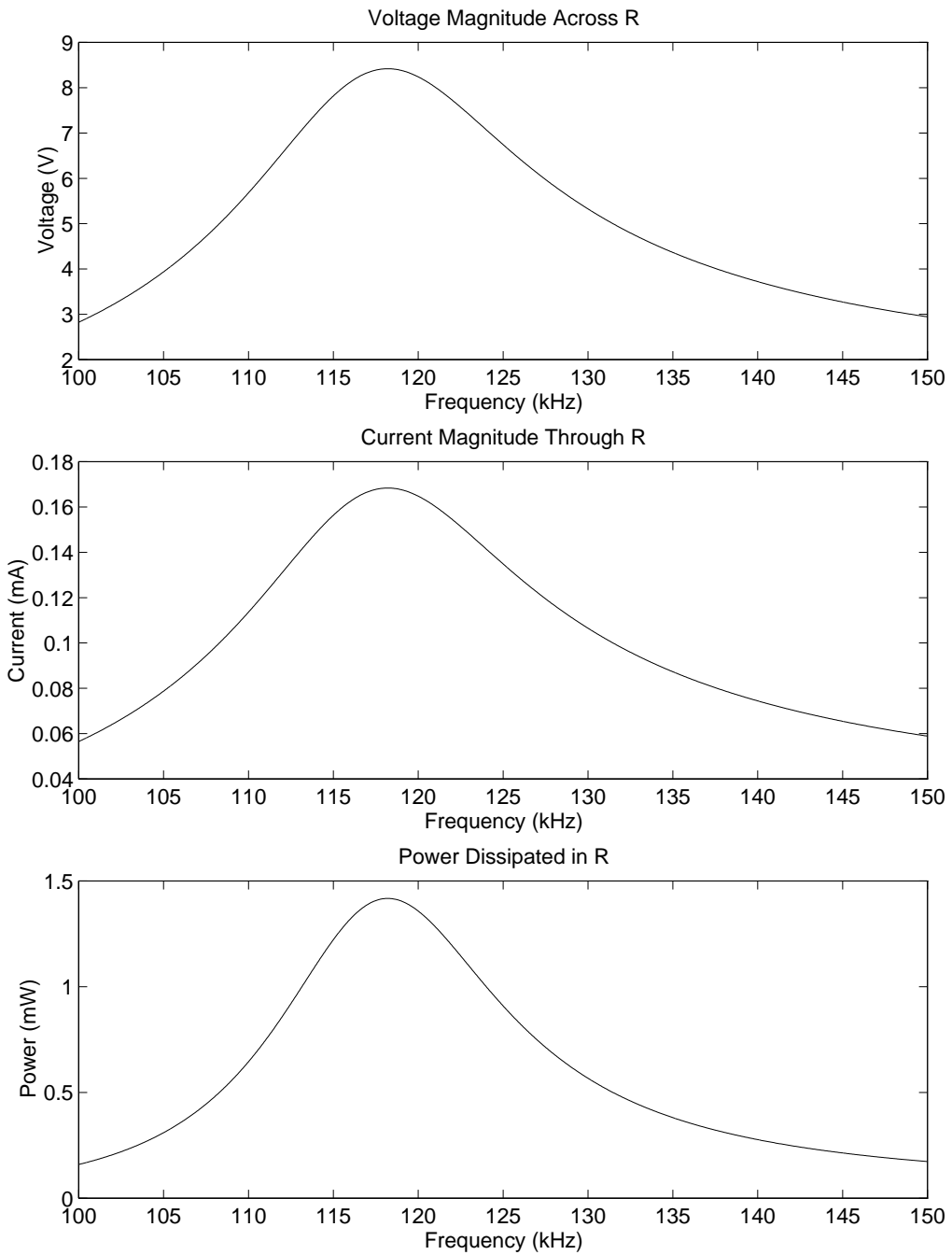

Figure 2-5: Voltage, Current, and Power across the tag electrodes vs. reader frequency for $R = 50 \text{ k}\Omega$.

Chapter 3

Loading Mode

In this chapter, I describe the loading mode tag and reader.

3.1 What is Loading Mode?

Loading mode is a method that a tag can use to send digital data to the reader. The tag modulates the load that it presents to the reader to send bits to the reader. Post first discovered that loading could be measured through the body. Referring back to Figure 2-1, the reader sees a Thevenin equivalent impedance, Z_{th} . The tag modulates Z_{th} by modulating its own component values. There are at least two ways the tag can do this. First, the tag can switch its Q by switching in a parasitic resistor, R_p , as in Figure 3-1 or by switching in two clamping diodes. This is called *Q-switching*. Second, the tag can switch its resonant frequency by switching in a capacitor instead of a resistor. We will call this *frequency shift keying (FSK)* because the tag is modulating its resonant frequency. Conventional magnetostatic RFID tags use both methods of data transmission among other methods such as Binary Phase Shift Keying (BPSK).

To power the electronics that drive the Q -switching or FSK, the tag draws power from the current flowing through it. We modeled the power dissipation of the tag electronics as a parallel tag resistance R in Section 2.4.

3.2 How do we Receive Data from the Tag?

At the tag's resonant frequency, the reader sees a mainly capacitive load. That is, the phase of Z_{th} is approximately $-\pi/2$. Figure 3-2 shows the magnitude and phase of Z_{th} as a function of R with $f_r = 125$ kHz for the parameter values used in Section 2.4. Figure 3-3 shows the f_r dependence of Z_{th} for $R = 50$ k Ω . Figure 3-2 supports the approximation that the phase of Z_{th} is approximately $-\pi/2$.

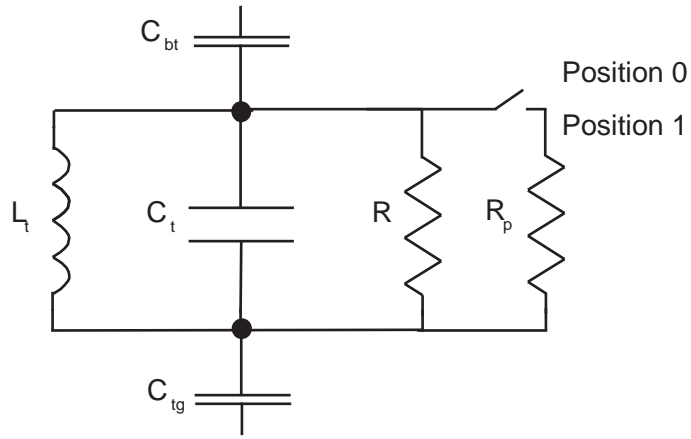

Figure 3-1: Loading mode tag with Q -switching data transmission.

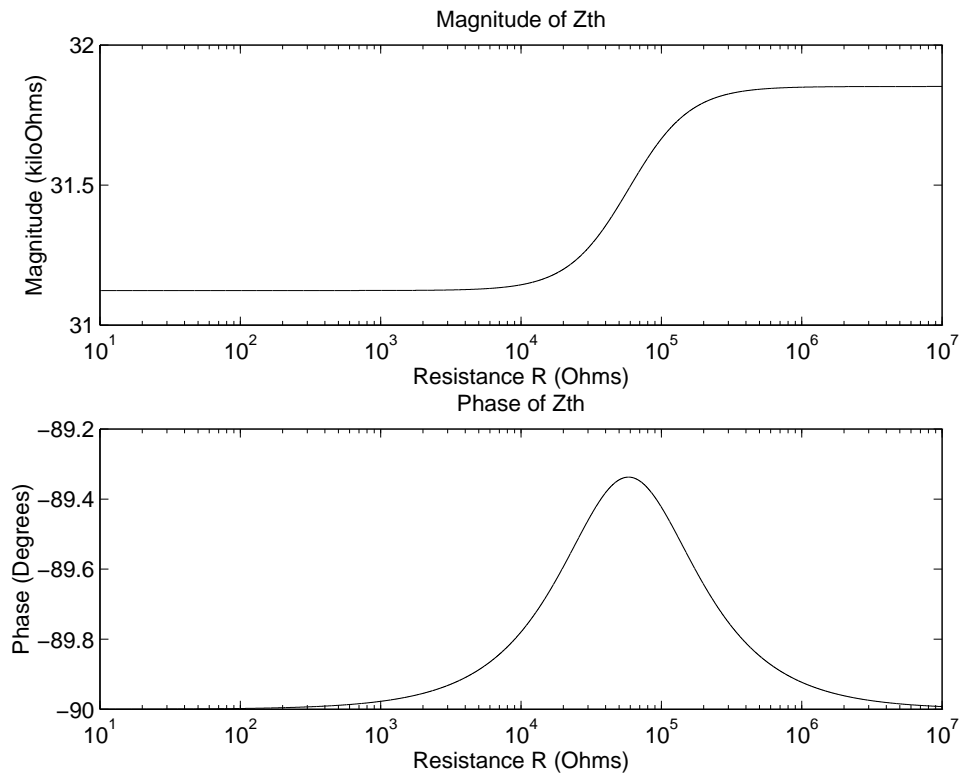

Figure 3-2: Magnitude and Phase of Z_{th} as a function of R with $f_r = 125$ kHz.

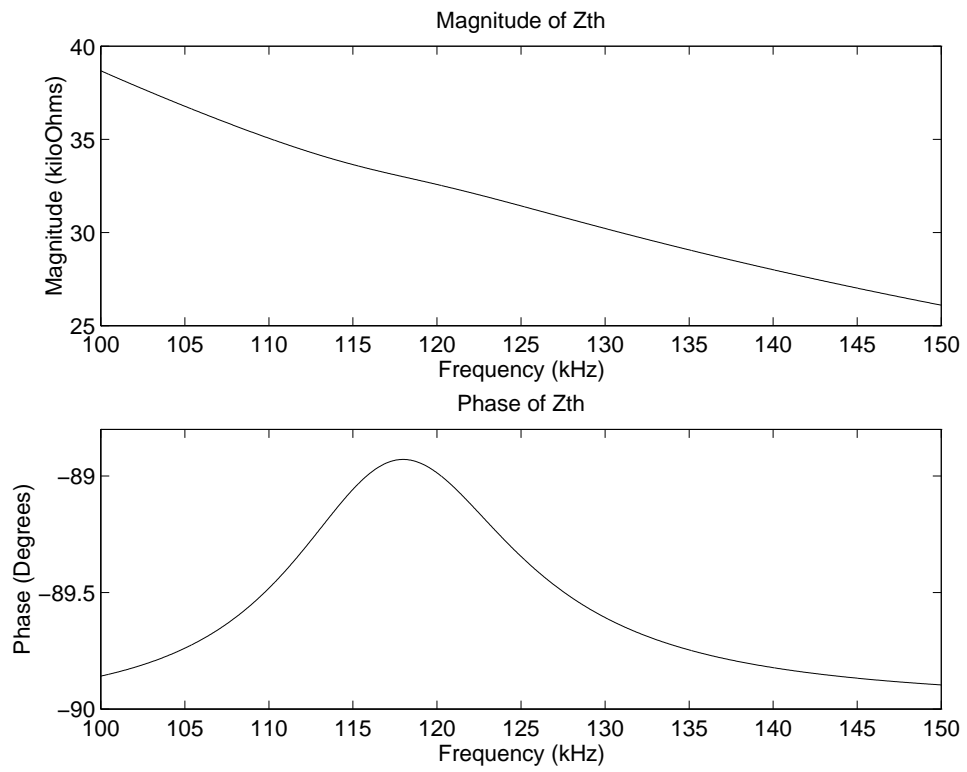

Figure 3-3: Magnitude and Phase of Z_{th} as a function of f_r with $R = 50 \text{ k}\Omega$.

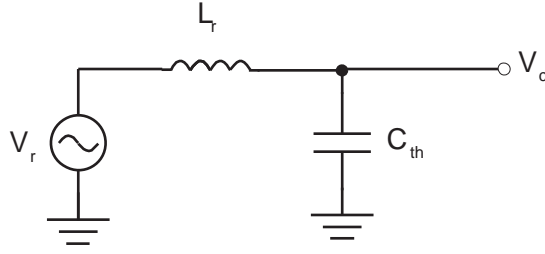

Figure 3-4: The LC-tank used to detect the bits coming from the tag ($V_{C_{th}} = V_C$).

Therefore, we define $Z_{th} = 1/j\omega C_{th}$ where C_{th} is a real number. We will work with the approximation that Z_{th} is capacitive for the rest of this chapter.

We assume that when the tag sends bits back to the reader by Q -switching or FSK only the value of C_{th} changes. That is, the phase of Z_{th} remains $-\pi/2$. In observations made with the loading mode tag and reader, the phase of Z_{th} changed by only a few degrees as the tag modulated its impedance.¹

Now we have reduced the problem of detecting the bits coming from the tag to the problem of measuring a digitally modulated capacitance C_{th} . Here we use a sensitive method to detect changes in capacitance: put C_{th} in an LC-tank as in Figure 3-4 and drive the tank at its resonant frequency. Let's assume that an unpowered tag has its Q or FSK switch in position 0 and that C_{rb} , C_{bt} , C_{bg} , and C_{tg} are fixed at *nominal values*. In this configuration, we calculate the value of C_{th} and call it C_0 . This corresponds to the tag sending back a 0 bit. When the tag wants to send a 1 bit, it moves its switch to position 1, and assuming that C_{rb} , C_{bt} , C_{bg} , and C_{tg} are still at their nominal values, we calculate C_{th} again and call this new value C_1 . If we drive the tank at $\omega_r = 1/\sqrt{LC_0}$, we will be able to detect a 1 bit from the tag ($C_{th} = C_1$) by detecting a change in the amplitude or phase of $V_{C_{th}}$. Alternatively, we can also detect a change in the resonant frequency of the tank from $\omega = 1/\sqrt{LC_0}$ to $\omega = 1/\sqrt{LC_1}$.²

Why do I say this is a sensitive method to detect changes in C_{th} ? For a fixed C_{th} , say $C_{th} = C_0$, the amplitude of the transfer function $V_{C_{th}}/V_r$ of a high Q reader tank has a large slope off resonance and the phase of the transfer function has a large slope on resonance. Therefore any deviation of C_{th} from C_0 results in a large change in the voltage and phase of $V_{C_{th}}$.

¹It may be possible to improve the sensitivity of the tag reader by detecting these phase changes.

²Note that C_0 and C_1 may not necessarily correspond to the tag sending a 0 or 1 bit to the reader. Instead, these two levels may be used to form bits as in Manchester encoding. I will ignore this distinction even though the chip used in loading mode tag (Section 3.3.1) transmits Manchester encoded data.

3.3 Implementation of the Loading Mode Tag and Reader

Thus far, we have discussed loading mode tags and readers in the abstract. Here, we will discuss the loading mode tag and reader implementation at a systems level. The actual schematics, code, and implementation details can be found in Appendix B.

3.3.1 The Loading Mode Tag

The tag consists of a 9.5 mH inductor (L_t), a V4050 magnetostatic RFID chip from EM Micro-electronic-Marin SA [6], and two electrodes. The 4050 contains an integrated 170 pF capacitor (C_t). Thus the tag is resonant at 125 kHz. The geometry is the same as in Figure 3-1 except C_t , R , and R_p are integrated into the 4050.

The 4050 is a 2-pin device that transmits data by Q-switching and contains 1 kilobit of EEPROM that we can program *through the body*. The 4050 derives its internal clock from the frequency of the voltage across its pins and transmits Manchester encoded data at 1/64th of this frequency. Therefore, in our implementation, with a reader frequency of 125 kHz, the bit rate is $125\text{kHz}/64 = 1.95\text{kHz}$. Though the 4050 was designed for magnetostatic applications, it is simple to modify it to function as a bodytag by adding an inductor to make the tag resonant and adding one electrode to couple the tag to the body (C_{bt}) and another electrode to couple the tag to ground (C_{tg}).

I stated earlier that a large part of the cost of a traditional magnetostatic RFID tag is in the cost of the tag's coil. The bodytag is cheaper than a magnetostatic tag: a coil has been replaced with two electrodes and a lumped element inductor. We may also be able to remove the inductor without adversely decreasing the tag's read range or increasing the errors in the tag's data transmission. I have demonstrated that the loading mode system presented here functions without L_t .

A word or two is in order about the term "read range" in the context of bodytags. What does it mean? Though Nicky's hand is never in physical contact with the reader electrode, it is usually within millimeters of the electrode when the reader is interrogating the bodytag. However, our loading mode system has been shown to function correctly when the user's foot is as far as 3 cm away from the tag's top electrode. Thus in the context of bodytags, the term "read range" refers the maximum distance between Nicky's hand and the reader, Nicky's foot and the tag, or the tag and ambient ground. Read range is therefore a measure of the robustness of the bodytag system.

There are many other magnetostatic RFID chips on the market that can also be modified to function as a bodytag. Data transmission strategies used by these chips include Q-switching, FSK, phase shift keying (PSK), and spread spectrum techniques. I have not investigated the use of any of these tags for bodytag applications.

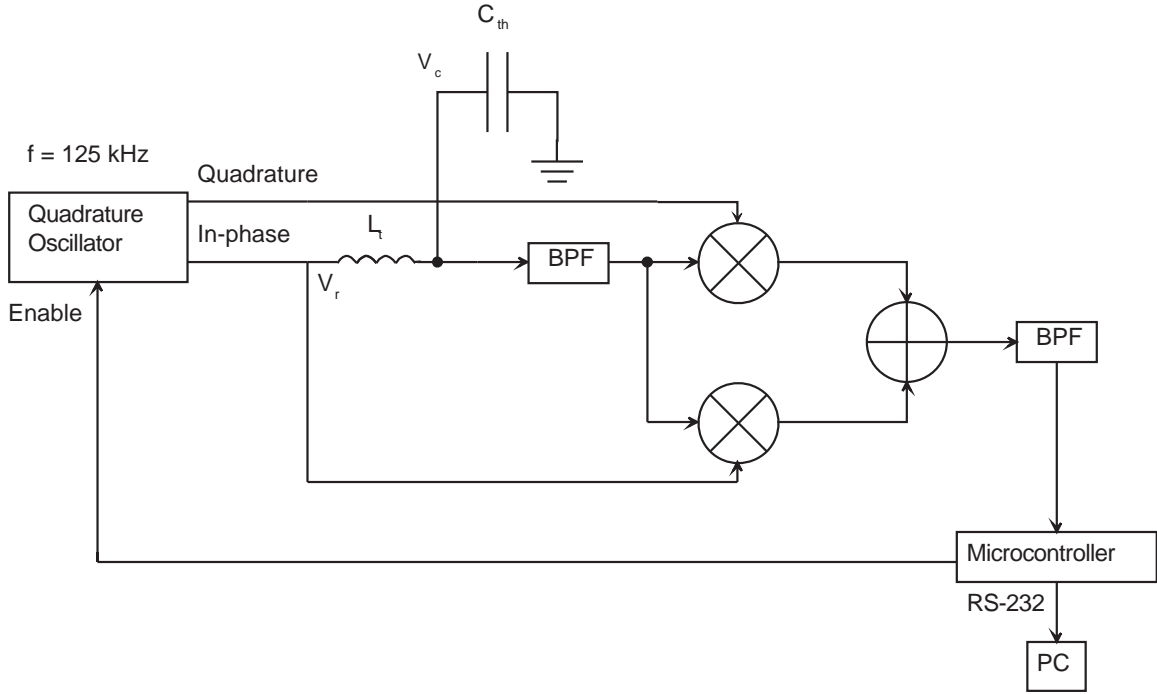

Figure 3-5: Block diagram of the loading mode reader.

A quadrature sine wave oscillator drives the reader's LC tank. The output of the tank is band pass filtered (BPF) to remove noise and interference in $V_{C_{th}}$. The signal is then quadrature demodulated and band-pass filtered to pull out the baseband signal. The demodulated data goes to a PIC16LF84 microcontroller which passes the data onto a PC. The PIC can disable the oscillator to transmit data to the body tag by 100% amplitude modulation of $V_{C_{th}}$. Again, $V_C = V_{C_{th}}$.

3.3.2 The Loading Mode Reader

Basic Detection Strategy

A system level diagram of the loading mode reader is shown in Figure 3-5. I use the LC-tank method described above to detect the digital modulation of C_{th} . The tank is driven at $\omega_r = 1/\sqrt{L_r C_0}$ with L_r chosen to give a tank resonant frequency that coincides with tag's resonant frequency, $f = 125\text{kHz}$. It is important not to confuse the resonant frequency of the tag at $\omega = 1/\sqrt{L_t C_t}$ and the resonant frequency of the reader LC-tank at $\omega = 1/\sqrt{L_r C_{th}}$. I state again that L_r is chosen so that these resonances coincide at 125 kHz when $C_{th} = C_0$.

Quadrature Detection

Though the Q -switching 4050 amplitude modulates (AM) C_{th} , I used quadrature, rather than synchronous detection, to pull out the baseband signal from $V_{C_{th}}$. There are two good reasons to choose quadrature over synchronous detection in this scenario.

First, $V_{C_{th}}$ changes in both amplitude and phase as the 4050 sends bits back to the reader and

C_{th} moves off (C_1) and on (C_0) resonance.

Second, the reader operates at a fixed frequency $\omega_r = 1/\sqrt{L_r C_0}$ under the assumption that $C_{th} = C_0$ when the tag is sending a 0 bit. However, this assumes that C_{rb} , C_{bg} , C_{bt} , and C_{tg} are all at their nominal values. Yet C_{rb} , C_{bg} , C_{bt} , and C_{tg} respectively depend on how well Nicky couples to the reader, how well Nicky couples to ground, how well Nicky's foot couples to the tag, and how well the tag couples to ground. Therefore when the tag transmits a 0, C_{th} may not be equal to C_0 and when the tag transmits a 1, C_{th} may not be equal to C_1 if C_{rb} , C_{bg} , C_{bt} , and C_{tg} are not at their nominal values. In fact, we cannot depend on C_{rb} , C_{bg} , C_{bt} , and C_{tg} to be at their nominal values. Their values will change depending on how well Nicky couples to the reader, ground, and the tag and how well the tag couples to ground.

Assume that the tag is transmitting a 0 but some of C_{rb} , C_{bg} , C_{bt} , and C_{tg} are not at their nominal values. Then $C_{th} \neq C_0$ and the tank is not being driven at its resonant frequency because the reader frequency is fixed at $\omega_r = 1/\sqrt{L_r C_0}$. Then the phase of $V_{C_{th}}$ is shifted off its nominal value and we need quadrature detection to pull out the in-phase and quadrature component of the AM signal.

Note that if $C_{th} \neq C_0$ when the tag is transmitting a 0, then the sensitivity of the LC-tank detection strategy is reduced because the tank formed by L_r and C_{th} is not being driven at its resonant frequency. Again, C_{th} depends on C_{rb} , C_{bg} , C_{bt} , and C_{tg} which in turn depend on how well Nicky couples to the reader, ground, and the tag and how well the tag couples to ground. Since we cannot depend on C_{rb} , C_{bg} , C_{bt} , and C_{tg} to assume any nominal value, I present methods to automatically tune the reader's LC tank in Section 3.5.

Programming the Tag's EEPROM

The reader can communicate with the bodytag and program the bodytag's EEPROM through 100% amplitude modulation of the reader signal. The system presented here can program the bodytag's EEPROM through the body. The protocol for the reader to talk to the bodytag is described in the EM Microelectronic-Marin SA databook [6].

3.4 The Doorknob Demo

One of the main applications of magnetostatic RFID systems is for electronic access to buildings. Rather than using a key to unlock a door, the user brings a magnetostatic RFID tag near a magnetostatic reader located beside the door. The tag and reader exchange data and if the user is authorized, the door unlocks. To demonstrate the utility of the bodytag, I created what I call *the doorknob demo*. In this demo, the reader electrode is embedded in a brass doorknob which is covered by an insulator and the bodytag is embedded in Nicky's shoe. Nicky simply touches the doorknob,

the bodytag and reader exchange data and, if she is authorized, the door unlocks.

Our bodytag system would be more useful if the tag did not have to be embedded in Nicky's shoe but could be placed in her back pocket in the same form factor as a credit card. I discussed why this is difficult in Section 2.3 and I will present ideas on how we might do this in the next section and in Section 5.2.

3.5 Methods to Push the Performance of the Loading Mode Reader

In this section, I will describe methods to increase the read range and the robustness of the loading mode reader. None of these methods were used in the loading mode reader described above but I have realized some of these ideas.

Increasing the Voltage on the Reader Electrode

The voltage on the reader electrode is a function of the Q of the LC-tank formed by L_r and C_{th} and the voltage going into the tank. That is,

$$|V_{C_{th}}| \approx Q|V_r|.$$

This is a very good approximation for any tank with $Q > 5$. We can increase the Q of the tank by using a higher Q inductor and moving to higher reader frequencies where the practical Q of the inductor will be higher. One can also use a transformer instead of an inductor in this application to increase the voltage on the reader electrode.

Optimize the Reader Frequency

As I discussed in Section 2.2, there is likely an optimal frequency or frequencies where the tag receives maximal power and the tag signal is strongest. I have not yet determined these frequencies.

Increase the Tag's Q

Increasing the Q of the parallel tank in the tag will increase the tag's power-conversion efficiency as well as increase the read range of the system. Again, we can increase the tag tank Q by using a higher Q inductor for L_t and moving to higher frequencies where the Q of L_t is higher. However, economic concerns may dictate that we remove L_t from the tag altogether.

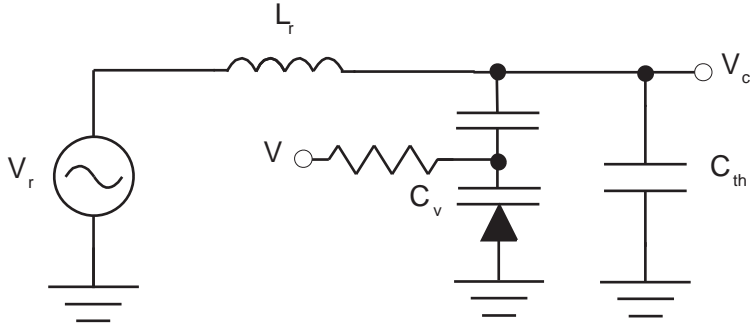

Figure 3-6: Using a varactor to control the resonant frequency of the tank ($V_{C_{th}} = V_C$)

Using a PLL or a Varactor Diode to Tune the Reader Tank

As I mentioned in Section 3.3.2, the reader's LC-tank is easily detuned if $C_{th} \neq C_0$ when the tag is transmitting a 0 bit. There are at least two feedback systems that can automatically keep the system tuned and circumvent this problem. The first is based on a Phase-Locked Loop (PLL) and the second is based on a varactor diode.

Since the phase of $V_{C_{th}}$ is exactly $-\pi/2$ when the reader tank is driven at its resonant frequency, $\omega = 1/\sqrt{L_r C_{th}}$, we can use a PLL to automatically adjust the reader frequency, ω_r , until the reader's tank is resonant. Therefore, we account for perturbations in C_{rb} , C_{bg} , C_{bt} , and C_{tg} from their nominal values by adjusting ω_r until the reader tank is resonant.

Aside from the normal tradeoffs in PLL design, the utility of this method is limited if the tag is also resonant. If ω_r deviates too much from the resonant frequency of the tag, $\omega = 1/\sqrt{L_t C_t}$, the tag's power conversion efficiency and transmission signal strength are reduced. However, this method *is* useful if the tag is not resonant.

I have successfully implemented this method using the CD74HC4046 PLL with a type II phase detector and a PLL bandwidth of approximately 25 Hz. A type II phase detector is necessary because we need a fixed phase shift between the two phase-locked signals in this application.

A reverse biased varactor diode acts as a voltage dependent capacitor [7]. We can use a varactor to keep the reader tank resonant as follows. Fix the reader frequency at $\omega_r = \omega_0 = 1/\sqrt{L_r C_0}$ and put the varactor in parallel with C_{th} as in Figure 3-6. Now we need a feedback system to set C_v so that the system is resonant at ω_0 for some range of C_{th} . We can use the same trick that I presented in the PLL method above. The phase of $V_{C_{th}}$ will be exactly $-\pi/2$ if the reader tank is resonant. Therefore we can use a PLL with a type II detector or another suitable feedback system to adjust V until the tank is resonant at ω_0 .

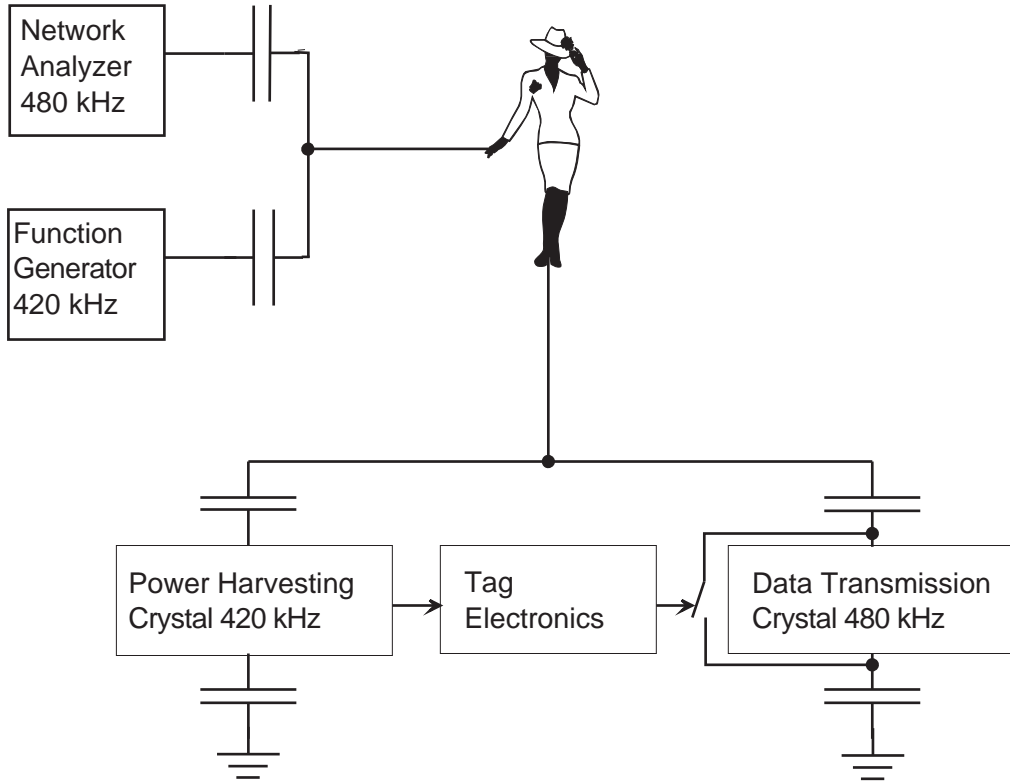

Figure 3-7: Block diagram of the loading mode crystal-based bodytag.

3.6 Some Comments on Loading

I conclude this chapter with a few comments on measuring loading in general.

RFID readers, including the loading mode reader presented here, operate at a fixed frequency and look for the modulation of a load in the time domain. An alternative method is to build a tag with several resonances in the the frequency domain and use these resonances to store bits [5]. For example, one can use high Q crystals ($Q > 100$) with various resonances embedded in the frequency domain as a tag. To read this tag we need any device that measures loading in the frequency domain such as a network analyzer.

I have also built loading mode tags that operate similarly to the 4050. Figure 3-7 presents the block diagram. A high Q crystal harvests power from the reader and another high Q crystal transmits data back to the reader. The power harvesting crystal was resonant at 420 kHz and the data transmission crystal was resonant at 480 kHz. The data transmission crystal was switched on and off in the time domain to transmit data. In this case, the reader was an HP 8753D Network Analyzer performing an S_{11} measurement. The network analyzer measured loading at 480 kHz on one reader electrode while a function generator put out a 10 V amplitude sine wave at 420 kHz on another reader electrode. The user touched both reader electrodes to initiate a tag interrogation.

Chapter 4

Transmit Mode

In this chapter I describe the transmit mode tag and reader. Transmit mode differs from loading mode in that in transmit mode, the tag actually transmits a signal back to the reader through the user's body. I have already described how the reader can transmit data and power through Nicky's body to the bodytag by electrostatically coupling to Nicky's body. Likewise, the tag can transmit a signal to the reader by electrostatically coupling a signal through Nicky's body.

This chapter will be brief because the transmit mode tag and reader are simple extensions of the PAN III transceiver designed by Reynolds and Post [3].

4.1 The Transmit Mode Bodytag

Reynolds and Post designed the PAN III transceiver, a half-duplex PAN transceiver that communicates with FSK at 2400 baud. The two FSK frequencies are 200 kHz and 250 kHz. The transmit mode bodytag is essentially a dedicated PAN III transmitter with its batteries removed (Figure 4-1).

The bodytag rectifies the current moving through the tag electrodes and uses the rectified current to power a PIC16LF84 microcontroller running at 8 MHz. The PIC then transmits FSK encoded ASCII data through a series LC tank to the reader. The PIC puts 2.5 V amplitude square wave into the LC tank and the tanks boosts the transmission voltage by a factor of the tank's $Q \approx 10$.

Note that the power comes in on one pair of electrodes and the data is transmitted on another pair of electrodes. This system would be much nicer if these electrodes could be combined into a single pair.

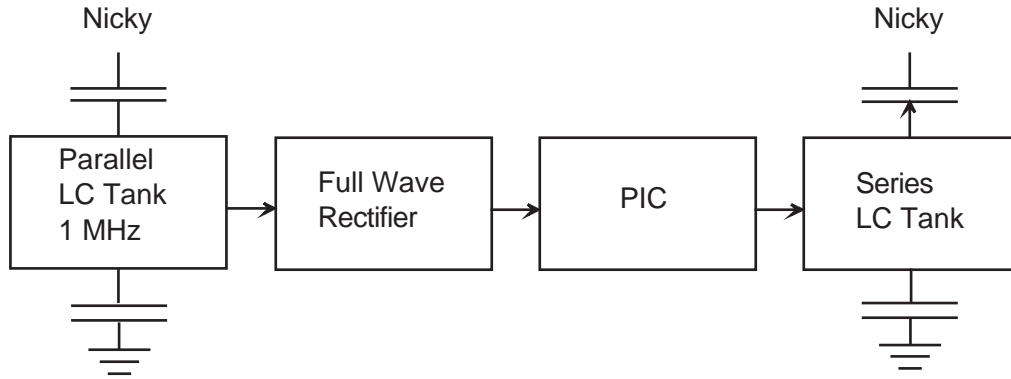

Figure 4-1: Block diagram of the transmit mode bodytag.

4.2 The Transmit Mode Reader

The transmit mode reader consists of two electrodes. One electrode is attached to a 50 V amplitude sine wave at 1 MHz. This electrode electrostatically powers the transmit mode tag through the tag's parallel LC tank.

The other electrode is attached to an unmodified PAN III receiver which is designed to demodulate the FSK data sent by the PAN III transmitter. The receiver demodulates the data with a PLL and transmits the ASCII data to a PC. The user touches both electrodes simultaneously to initiate a tag interrogation. Again, his system would be much nicer if these reader electrodes could be combined into a single electrode.

Chapter 5

Conclusions and Future Work

In this thesis I have presented a novel method to transmit data and power through the body. I applied this technology to an RFID bodytag that can transmit data through the user's body to an RFID reader. Furthermore, since the bodytag has an EEPROM, it can be seamlessly updated with new information at any time. Chapter 2 presented the model that shows how data and power can be transmitted through the body. Chapter 3 presented the loading mode bodytag and Chapter 4 presented the transmit mode bodytag. I will conclude by briefly addressing the health concerns associated with exposure to electric fields. I will then present some ideas on how to improve the performance of the bodytag system presented here.

5.1 Health Concerns

There is a lot of hype, paranoia, and legitimate concern associated with exposure to electric fields. Suffice it to say that the effects of electromagnetic fields on human beings are not well understood and I will not make any attempt to clear up the matter. The FCC has published guidelines on human exposure to electromagnetic fields [8] but these requirements are not enforced by law. Furthermore, whether these requirements are too harsh or too lenient is an open question. Recently, a study by the National Academy of Sciences has concluded that

Based on a comprehensive evaluation of published studies relating to the effects of power-frequency electric and magnetic fields on cells, tissues, and organisms (including humans), the conclusion of the committee is that the current body of evidence does not show that exposure to these fields presents a human-health hazard [9].

The FCC guidelines cite ANSI/IEEE C95.1-1992 which indicates a maximum near-field electric field exposure of 614 V/m for frequencies below 3 MHz [8]. ANSI/IEEE C95.1-1992 also sets the maximum displacement current through one foot at 45 mA for the .1-100 MHz frequency range.

These figures are for an “uncontrolled” environment averaged over a 6 minute time interval. Both the loading mode tag and reader operate well below these guidelines.

5.2 Thoughts on How to Move the Tag out of the Shoe and into the Back Pocket

The bodytag would be much more useful if it did not have to be embedded in the user’s shoe to function properly. As I discussed in Section 2.3, breaking symmetry is the fundamental limitation that has to be addressed if we want the bodytag to work in the user’s back pocket.

In Section 3.5 I discussed how we might push the performance of the loading mode reader. The following list summarizes that section, listing ways that we can increase the read range of the loading mode and transmit mode bodytag.

- Make the tag resonant.
- Increase the voltage on the reader electrode.
- Find the optimal frequencies for power and data transmission through the body.
- Implement a feedback system in the reader to keep the load that the reader sees resonant at the reader’s operating frequency.

It remains to be seen whether these improvements will allow us to read a bodytag in the user’s back pocket.

Another issue I have not addressed is whether transmit mode or loading mode bodytags will have the largest read range. The power requirements of a loading mode bodytag are currently much less than those of a transmit mode bodytag. Loading mode bodytags dissipate microwatts of power whereas transmit mode bodytags currently dissipate milliwatts of power.¹

However, a battery-powered PAN III transmitter can transmit data from the user’s back pocket to a PAN III receiver. It has not yet been shown that a battery-powered loading-mode tag can robustly transmit data from the user’s back pocket.

We currently are not able to effectively decide whether loading or transmit mode will be more robust in a certain situation.

5.3 Final Comments

The bodytag technology is currently very promising but there is still practical and theoretical work to be done in this area. The bodytag has two important advantages over a traditional magnetostatic

¹To date, there has been no work on designing micropower transmit mode ASICs.

RFID tag.

The bodytag is cheaper than a magnetostatic RFID tag. The market infiltration of an RFID system is likely directly related to the quotient

$$\frac{\text{\# of bits stored in tag}}{\text{cost of tag}}$$

The bodytag can store as many bits as any magnetostatic RFID tag but it is substantially cheaper.

The bodytag is wearable. The user does not need to bring the tag to the reader. The user presents the tag to the reader simply by bringing his hand or another body part near the reader. The presentation of the tag to the reader is embedded in a very natural gesture. The bodytag is a step towards natural and transparent human-computer interaction.

Appendix A

Matlab Code for Power Calculations

This appendix contains the Matlab code that we used to make the calculations in Section 2.4. Section A.1 contains the code to calculate the parameter's R dependence and Section A.2 contains the code to calculate the f_r dependence.

A.1 R Dependence

```
% For each entry in R (the resistances we want to look at), we
% calculate the voltage across the resistor, the current through the
% resistor, and the power dissipated by the resistor and store these
% in Voltage, Current, and Power.
%
% We also calculate the thevenin equivalent impedance seen by the reader
% and store this in Impedance.

% Evaluate for these resistance values.
R = logspace(1,7,1e4);

% Voltage across R.
Voltage = ones(size(R));
% Current through R.
Current = ones(size(R));
% Power dissipated in R.
Power = ones(size(R));
% Impedance seen by reader.
Impedance = ones(size(R));

% Reader operating frequency.
f = 125e3;
w = 2*pi*f;
```

```

% Reader voltage magnitude in volts. We ignore phase in all
% of these calculations.
V = 50;

% Component Values in farads, henries, and ohms.
Crb = 50e-12;
Cbg = 200e-12;
Cbt = 50e-12;
Lt = 9.5e-3;
Ct = 170e-12;
Ctg = 50e-12;

% Impedance Values.
Xrb = 1 / (j*w * Crb);
Xbg = 1 / (j*w * Cbg);
Xbt = 1 / (j*w * Cbt);
XLt = j*w * Lt;
XCt = 1 / (j*w * Ct);
Xtg = 1 / (j*w * Ctg);

% Main loop.
for i = 1:size(R,2)

    %Calculate impedance seen by reader.

    % Impedance of tag.
    XTag = (XLt * XCt * R(i)) / (XLt*XCt + XLt*R(i) + XCt*R(i));

    % Impedance of right most leg.
    XTagLeg = Xbt + XTag + Xtg;

    % Impedance seen by reader.
    XEverything = Xrb + (Xbg * XTagLeg) / (Xbg + XTagLeg);
    Impedance(i) = XEverything;

    % Calculate current out of reader.
    IReader = V / XEverything;

    % Calculate current through tagleg using
    % admittances (current divider).
    ITagLeg = IReader * (1/XTagLeg) / ((1/XTagLeg) + (1/Xbg));

    % Calculate voltage magnitude across right most leg.
    VTagLeg = ITagLeg * XTagLeg;

    % Calculate voltage across tag (voltage divider).
    VTag = VTagLeg * (XTag) / (Xbt + XTag + Xtg);

    Power(i) = real(VTag * conj(ITagLeg));
    Voltage(i) = abs(VTag);
    Current(i) = Voltage(i) / R(i);
end

```

```

% Create plots.

subplot(211);

semilogx(R,abs(Impedence)/1000,'y-');
title('Magnitude of Zth');
xlabel('Resistance R (Ohms)');
ylabel('Magnitude (kiloOhms)');

subplot(212);

semilogx(R,phase(Impedence)/pi*180, 'y-');
title('Phase of Zth');
xlabel('Resistance R (Ohms)');
ylabel('Phase (Degrees)');
orient portrait
print -deps loading-zth-r.ps

subplot(311);

semilogx(R,Voltage, 'y-');
title('Voltage Magnitude Across R');
xlabel('Resistance R (Ohms)');
ylabel('Voltage (V)');

subplot(312)

semilogx(R,Current*1000, 'y-');
title('Current Magnitude Through R');
xlabel('Resistance R (Ohms)');
ylabel('Current (mA)');

subplot(313)

semilogx(R,Power*1000, 'y-');
title('Power Dissipated in R');
xlabel('Resistance R (Ohms)');
ylabel('Power (mW)');
orient tall

print -deps model-power-r.ps

hold off

```

A.2 f_r Dependence

```

% For each entry in w (the frequencies we want to look at), we
% calculate the voltage across the resistor, the current through the
% resistor, and the power dissipated by the resistor and store these
% in Voltage, Current, and Power.

```

```

%
% We also calculate the thevenin equivalent impedance seen by the reader
% and store this in Impedence.

% Evaluate for these resistance values.
R = 50e3;

% Reader operating frequency.
f = linspace(100e3,150e3,1e3);
w = 2*pi*f;

% Voltage across R.
Voltage = ones(size(w));
% Current through R.
Current = ones(size(w));
% Power dissipated in R.
Power = ones(size(w));
% Impedence seen by reader.
Impedence = ones(size(w));

% Reader voltage magnitude in volts. We ignore phase in all
% of these calculations.
V = 50;

% Component Values in farads, henries, and ohms.
Crb = 50e-12;
Cbg = 200e-12;
Cbt = 50e-12;
Lt = 9.5e-3;
Ct = 170e-12;
Ctg = 50e-12;

% Main loop.
for i = 1:size(w,2)

    % Impedence Values.
    Xrb = 1 / (j*w(i) * Crb);
    Xbg = 1 / (j*w(i) * Cbg);
    Xbt = 1 / (j*w(i) * Cbt);
    XLt = j*w(i) * Lt;
    XCt = 1 / (j*w(i) * Ct);
    Xtg = 1 / (j*w(i) * Ctg);

    %Calculate impedance seen by reader.

    % Impedence of tag.
    XTag = (XLt * XCt * R) / (XLt*XCt + XLt*R + XCt*R);

    % Impedence of right most leg.
    XTagLeg = Xbt + XTag + Xtg;

    % Impedence seen by reader.
    XEverything = Xrb + (Xbg * XTagLeg) / (Xbg + XTagLeg);
    Impedence(i) = XEverything;

```

```

% Calculate current out of reader.
IReader = V / XEverything;

% Calculate current through tagleg using
% admittances (current divider).
ITagLeg = IReader * (1/XTagLeg) / ((1/XTagLeg) + (1/Xbg));

% Calculate voltage magnitude across right most leg.
VTagLeg = ITagLeg * XTagLeg;

% Calculate voltage across tag (voltage divider).
VTag = VTagLeg * (XTag) / (Xbt + XTag + Xtg);

Power(i) = real(VTag * conj(ITagLeg));
Voltage(i) = abs(VTag);
Current(i) = Voltage(i) / R;
end

% Create plots.

subplot(211);

plot(f/1000,abs(Impedence)/1000,'y-');
title('Magnitude of Zth');
xlabel('Frequency (kHz)');
ylabel('Magnitude (kiloOhms)');

subplot(212);

plot(f/1000,phase(Impedence)/pi*180, 'y-');
title('Phase of Zth');
xlabel('Frequency (kHz)');
ylabel('Phase (Degrees)');
orient portrait
print -deps loading-zth-w.ps

subplot(311);

plot(f/1000,Voltage, 'y-');
title('Voltage Magnitude Across R');
xlabel('Frequency (kHz)');
ylabel('Voltage (V)');

subplot(312)

plot(f/1000,Current*1000, 'y-');
title('Current Magnitude Through R');
xlabel('Frequency (kHz)');
ylabel('Current (mA)');

subplot(313)

plot(f/1000,Power*1000, 'y-');

```

```
title('Power Dissipated in R');  
xlabel('Frequency (kHz)');  
ylabel('Power (mW)');  
orient tall  
print -deps model-power-w.ps
```

```
hold off
```

Appendix B

Implementation of the Loading Mode Reader

This section describes in detail the loading mode reader described in Section 3. I first present and discuss the circuitry of the loading mode reader and then present the quadrature oscillator and microcontroller code.

B.1 Loading Mode Reader Schematic

See Figure B-1 for the loading mode schematic. Beginning at the top left hand corner of Figure B-1 is a PIC16C71 used as a stable oscillator at 125 kHz. Using a PIC as an oscillator is admittedly overkill but the design is quick and easy. The code for the 16C71 can be found in Section B.2. The 16C71 puts out a square wave at 125 kHz on RB0 that is then AC-coupled, amplified and used to drive the reader LC-tank consisting of L_r and C_{th} . U1A (an AD712) sniffs $V_{C_{th}}$ and passes it through a band pass filter (BPF) centered at 125 kHz. The BPF is formed by an LC tank. The signal then goes to the AD734 multipliers to be quadrature demodulated.

The 16C71 also puts out a 125 kHz square wave on RB1 that is passed through a BPF to produce a sine wave that goes to one of the '734s to mix down the in-phase component of the signal from U2B. The output of the BPF goes through an LC tank to produce another sine wave with a $-\pi/2$ phase shift relative to the first sine wave. The phase shifted sine wave goes to the other '734 to mix down the quadrature component of the signal from U1B.

The outputs of the '734s are summed, AC-coupled and put through a 4-pole Chebyshev active low-pass filter with an $f_{3dB} = 8$ kHz. Theoretically, the outputs of the '734s should be squared then added. But in practice, they are usually just added in the name of a simple circuit design. The baseband signal then goes to a comparator with an adjustable threshold and then onto a PIC16F84

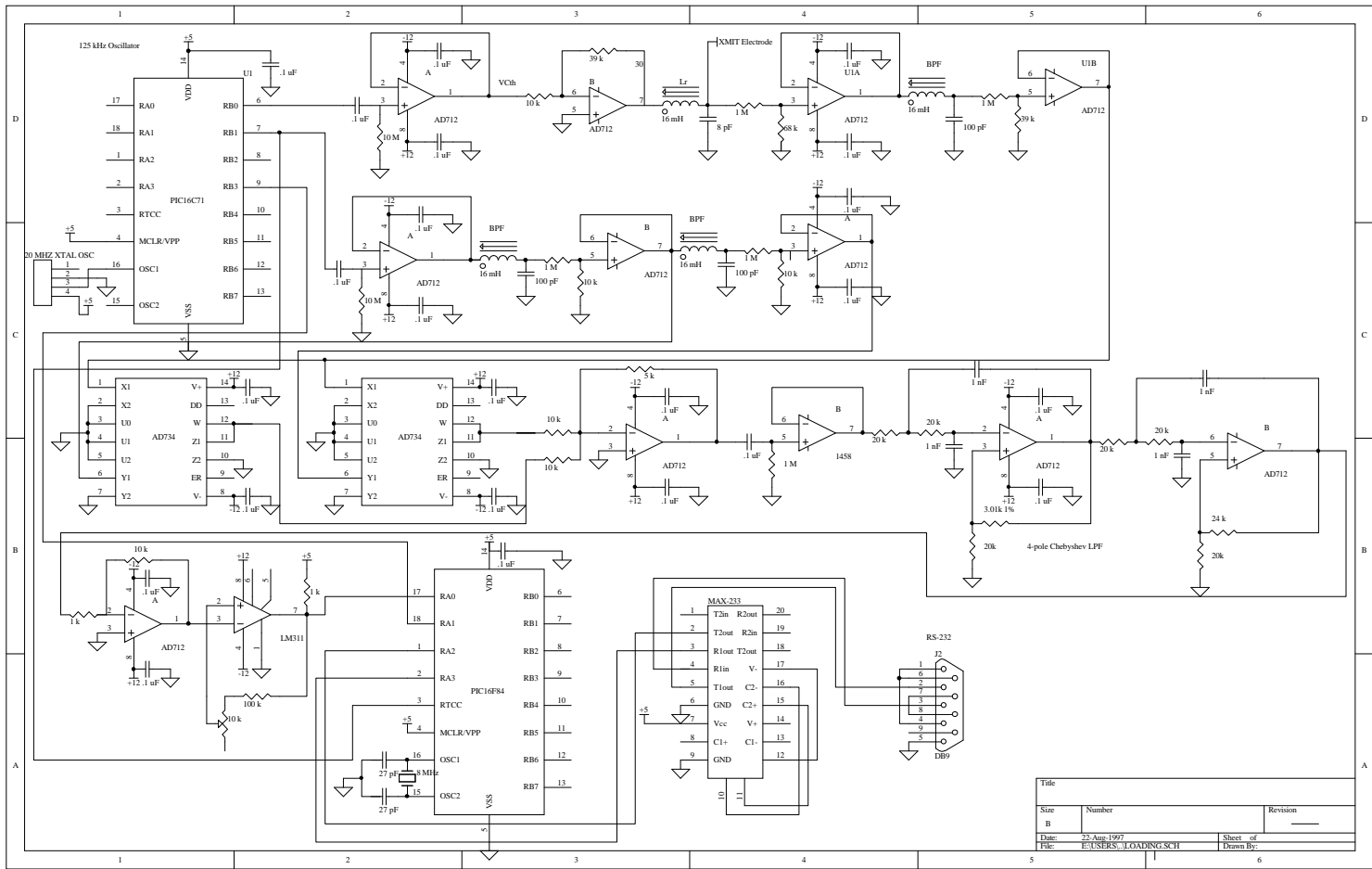

Figure B-1: Loading mode reader schematic.

microcontroller. The 16F84 is responsible for decoding the words from the bodytag and sending them as ASCII text through the MAX233 out to the RS-232 port of a PC. The 16F84 also enables and disables the 16C71's RB0, turning the reader LC-tank drive on and off. This lets us 100% amplitude modulate the signal on the transmit electrode to transmit digital data from the reader to the bodytag.

B.2 Oscillator Code

This section contains the 16C71 assembly code for the 125 kHz oscillator.

```

; Clock is assumed to be 20MHz internal oscillator
; Set device to PIC16C71, hex radix for all calculations
processor      16C71
__config B'1111111111010'; /CP,/WDTE,HS.
           radix      hex

; Defines for PIC16C71

PORTA equ 05 ; Register mapping for PORTA
PORTB equ 06 ; Register mapping for PORTB
STATUS equ 03 ; Status register
CARRY equ 0 ; Carry bit in status register
ZERO equ 2 ; Zero bit in status register
SAME equ 1 ; Destination register same as source reg
RPO equ 5 ; Bit 5 is RPO
C equ 0 ; Carry bit of STATUS register
TRISA equ 85 ; TRISA in Bank 1
TRISB equ 86 ; TRISB in Bank 1
RBPU equ 7 ; /RBPU in OPTION
OPT equ 81 ; OPTION register in Bank 1
w equ 0 ; Put back into w
self equ 1 ; Put back into same register.
RTCC equ 1 ; RTCC in Bank 0

;; Hardware specific defines.

on equ 0x03 ; Should we transmit to the bodytag?

;; Program.

org 0x0000 ; Reset vector
goto 0x0005 ; Jump to Main

org 0x0005 ; Start here.

main
init clrf PORTB
bsf STATUS, RPO ; Select Bank 1.
movlw 0x08 ; PORTB<3> is enable bit input.

```

```

movwf TRISB
bcf STATUS, RP0 ; Select Bank 0.

;; Clear PORTB.
movlw 0x00
movwf PORTB

;; Main loop.
;; PORTB<0> is the transmit signal.
;; PORTB<1> is the in-phase signal.
    ;; This signal also goes to the microcontroller pic TOCKI pin.
;; PORTB<2> is the quadrature signal. This is not used.
;; PORTB<3> enables PORTB<0>.

loop btfsc PORTB, on
goto enable
goto disable

enable movlw B'00000001'; Turn on PORTB
movwf PORTB
nop
nop
nop
nop
nop
nop
nop
nop
nop
nop
movlw B'00000011'
movwf PORTB
nop
nop
nop
nop
nop
nop
nop
nop
nop
nop
movlw B'00000110'
movwf PORTB
nop
nop
nop
nop
nop
nop
nop
nop
nop
nop
movlw B'00000100'
movwf PORTB
nop
nop
nop
goto loop

```

```

disable movlw B'00000000'; Turn on PORTB
movwf PORTB
nop
nop
nop
nop
nop
nop
nop
nop
nop
movlw B'00000010'
movwf PORTB
nop
nop
nop
nop
nop
nop
nop
nop
nop
nop
movlw B'00000110'
movwf PORTB
nop
nop
nop
nop
nop
nop
nop
nop
nop
movlw B'00000100'
movwf PORTB
nop
nop
goto loop

END

```

B.3 Microcontroller Code

This section contains the 16F84 assembly code for the reader microcontroller. Refer to the EM Microelectronic-Marin SA databook for the communication protocol with the V4050 [6]. The code is currently convoluted but it successfully communicates with the bodytag and can program it's EEPROM through the body.

```

; Clock is assumed to be 8MHz internal oscillator
; Set device to PIC16F84, hex radix for all calculations
processor      16F84
__config B'1111111110010'; PWRTE,/WDTE,HS.

```

```

                radix        hex

; Defines for PIC16F84

PORTA equ 05 ; Register mapping for PORTA
PORTB equ 06 ; Register mapping for PORTB
STATUS equ 03 ; Status register
CARRY equ 0 ; Carry bit in status register
ZERO equ 2 ; Zero bit in status register
SAME equ 1 ; Destination register same as source reg
RPO equ 5 ; Bit 5 is RPO
C equ 0 ; Carry bit of STATUS register
TRISA equ 85 ; TRISA in Bank 1
TRISB equ 86 ; TRISB in Bank 1
RBPU equ 7 ; /RBPU in OPTION
OPT equ 81 ; OPTION register in Bank 1
w equ 0 ; Put back into w
self equ 1 ; Put back into same register.
RTCC equ 1 ; RTCC in Bank 0
TMRO equ 0x01 ; TMRO in Bank 0.
INTCON equ 0x0B ; INTCON in Bank 0 and Bank 1.

;; Hardware specific defines.

INPUT equ 0 ; Data from tag on PORTA, PIN0.
XMIT equ 1 ; Turn coil on/off PORTA, PIN1.

;; Program Variables. General Purpose Registers to store data.

BIT equ 0x0C
TEMP equ 0x11
TRANSCOUNT equ 0x14
TEMP2 equ 0x15

;; Program.

org 0x0000 ; Reset vector
goto 0x0005 ; Jump to Main

org 0x0004 ; Interrupt Code.

org 0x0005 ; Start here.

main
init ;; Initialize registers.
bsf STATUS, RPO ; Select Bank 1.
movlw B'11111101'
movwf TRISA ; PORTA all inputs except bit1.
; PORTA<4> set to TOCKI.
; PORTA<1> is transmitter control.
movlw 0x00
movwf TRISB ; PORTB all outputs.
;; TIMERO stuff.
bsf OPT, 5 ; Counter mode for TIMERO.

```

```

bcf OPT, 4 ; Rising edge transition for TIMERO.
clrwdt ; How to change the prescaler from WDT to
; TIMERO.
bsf OPT, 3
bcf OPT, 2 ; Prescaler 1:1.
bcf OPT, 1
bcf OPT, 0
bcf INTCON, 5 ; Disable interrupts from TMRO overflow.
bcf STATUS, RPO ; Select Bank 0.
; ; Clear PORTB.
movlw 0x00
movwf PORTB
bsf PORTA, XMIT ; Turn on the transmitter.

; ; Done with initialization.
; ; Wait for 256 transitions before we assume that we have contact.
movlw 0xFF
movwf TRANSCOUNT
waitTrans
call trans
    decfsz TRANSCOUNT, self
goto waitTrans

; ; The tag stays high for 128 cycles of the carrier frequency in
; ; the LIW. We use this to sync to the LIW of the tag. 2 MHz /
; ; 125 kHz * 128 = 2048 PIC cycles 2048 PIC cycles = 128 * 16 so
; ; we listen for 13 successive highs, each high between 128 PIC
; ; cycles.

sync call liw
movwf TEMP ; Test return status of liw.
btfsc TEMP, 0
goto sync2 ; 128 carrier cycle high of LIW occurred.
call trans ; 128 carrier cycle high of LIW did not occur.
; Sync to next bit.
goto sync ; Start over.

sync2 call trans ; Skip ahead to the next 128 carrier cycle
; high before the FWR.
call trans
call trans
call trans
call liw ; See if we have another LIW.
movwf TEMP ; Test return status of liw.
btfsc TEMP, 0
goto write ; Second 128 carrier cycle high of LIW before
; FWR occurred.
call trans ; Second 128 carrier cycle high of LIW did not
; occur. Sync to next bit.
goto sync ; Start over.

login call trans ; Goto the low 64 carrier cycle part of LIW
; so we can send a RM.
call sendZero ; Send a zero to go into RM.

```

```
call sendZero ; Send second zero to go into RM.

call sendZero ; login command
call sendZero
call sendZero
call sendOne
call sendZero
call sendZero
call sendZero
call sendOne
call sendZero ; parity

call sendZero ; login0
call sendZero
call sendZero
call sendZero
call sendZero
call sendZero
call sendZero
call sendZero

call sendZero ; parity

call sendZero ; login1
call sendZero
call sendZero
call sendZero
call sendZero
call sendZero
call sendZero
call sendZero

call sendZero ; parity

call sendZero ; login2
call sendZero
call sendZero
call sendZero
call sendZero
call sendZero
call sendZero
call sendZero

call sendZero ; parity

call sendZero ; login3
call sendZero
call sendZero
call sendZero
call sendZero
call sendZero
call sendZero
call sendZero
```

```

call sendZero ; parity

call sendZero ; column parity
call sendZero
call sendZero
call sendZero
call sendZero
call sendZero
call sendZero
call sendZero

call sendZero ; Stop Bit.

waitForLIW
call liw
movwf TEMP ; Test return status of liw.
btfsc TEMP, 0
goto write ; 128 carrier cycle high of LIW occurred.
call trans ; 128 carrier cycle high of LIW did not occur.
; Sync to next bit.
goto waitForLIW ; Start over.

write
call trans ; Goto the low 64 carrier cycle part of LIW so
; we can send a RM.
call sendZero ; Send a zero to go into RM.
    call sendZero ; Send second zero to go into RM.

    call sendZero ; write command
    call sendZero
    call sendZero
    call sendOne
    call sendZero
    call sendZero
    call sendOne
    call sendZero

    call sendZero ; parity

    call sendZero ; address
    call sendZero
    call sendZero
    call sendZero
    call sendZero
    call sendOne
    call sendOne
    call sendOne

    call sendOne ; parity

call sendZero ; data0
call sendZero
call sendZero
call sendZero

```

```
call sendZero
call sendZero
call sendZero
call sendZero

call sendZero ; parity

call sendZero ; data1
call sendZero
call sendZero
call sendZero
call sendZero
call sendZero
call sendZero
call sendZero

call sendZero ; parity

call sendZero ; data2
call sendZero
call sendZero
call sendZero
call sendZero
call sendZero
call sendZero
call sendZero

call sendZero ; parity

call sendZero ; data3
call sendZero
call sendZero
call sendZero
call sendZero
call sendZero
call sendZero
call sendOne

call sendOne ; parity

call sendZero ; column parity
call sendZero
call sendZero
call sendZero
call sendZero
call sendZero
call sendZero
call sendZero
call sendOne

call sendZero ; "0"

call debug
goto sync
```

```
;; Send out a zero bit. The first part of a zero bit consists of 7
;; carrier cycles of transmitter on.
```

```
sendZero
movlw 0x00 ; Clear TMRO.
movwf TMRO
```

```
;; Send seven carrier cycles of transmitter on.
sendZeroSevenOn
movlw 0x04 ; If (TMRO - 4) - 1 = 0 then we are done with
; 7 carrier cycles of transmitter on.
subwf TMRO, w
movwf TEMP
decfsz TEMP
goto sendZeroSevenOn
```

```
;; Send 25 carrier cycles of transmitter off.
bcf PORTA, XMIT
movlw 0x00 ; Clear TMRO.
movwf TMRO
```

```
sendZeroTwentyFiveOff
movlw 0x18 ; If (TMRO - 24) - 1 = 0 then we are done with
; 25 carrier cycles of transmitter off.
subwf TMRO, w
movwf TEMP
decfsz TEMP
goto sendZeroTwentyFiveOff
```

```
;; Send 32 carrier cycles of transmitter on.
bsf PORTA, XMIT
movlw 0x00 ; Clear TMRO.
movwf TMRO
```

```
;; This part of the code depends on how the front end of the
;; reader acts during when the reader sends a zero bit. We may
;; have to modify this depending on different front ends.
```

```
sendZeroThirtyTwoOn
;; This is another way to do sendZeroThirtyTwoOn that does not sync
;; with the tag.
movlw 0x1F ; If (TMRO - 31) - 1 = 0 then we are done
; with 32 carrier cycles of transmitter off.
subwf TMRO, w
movwf TEMP
decfsz TEMP
goto sendZeroThirtyTwoOn
return
```

```
sendOne bsf PORTA, XMIT ; Turn on transmitter.
movlw 0x00 ; Clear TMRO.
movwf TMRO
sendOneWait
movlw 0x3F ; If (TMRO - 63) - 1 = 0 then we are done with
```

```

; 64 carrier cycles of transmitter on.
    subwf TMRO, w
    movwf TEMP
    decfsz TEMP
goto sendOneWait
return

;; Function liw assumes that we are near the beginning of a
;; new level. If the level stays high for 128 carrier cycles
;; then liw returns with 0xFF in w. Otherwise liw returns
;; with 0x00 in w. In either case, liw advances to the beginning
;; of the next level. liw modifies the TEMP, TEMP2, and W
;; registers.

liw
liwInit movlw 0x0E ; Store 13 in the TEMP register.
movwf TEMP

liwLoop btfss PORTA, INPUT ; Check if input is high.
goto liwFailure ; If no, return and report failure.
decfsz TEMP, self ; If yes, decrement TEMP; if TEMP = 0 goto
; next level, return, and report success.
goto liwWait ; Wait about 128 PIC cycles.
goto liwSuccess ; Goto next level, return, and report success.

liwWait ; Wait about 128 PIC cycles.
movlw 0x29
movwf TEMP2 ; TEMP2 = 41
liwWait2
decfsz TEMP2, self
goto liwWait2
goto liwLoop

;; There's a bug here somewhere. liwFailure gets called twice in a
;; row for some reason. However things still seem to work.

liwFailure ; We did not see 128 carrier cycles of high.
retlw 0x00 ; Report failure.

liwSuccess ; We saw 128 carrier cycles of high.
retlw 0x01 ; Report success.

;; Function trans waits until there is a transition in the bit
;; and stores the old bit in byte1 of BIT and the new bit in
;; byte0 of BIT. It assumes that the *current* new bit (the soon
;; to be old bit) is stored ;; in byte0 of BIT. It modifies the
;; TEMP register and the C bit of STATUS.

trans
;; Test to see if the bit has changed.
loop movlw 0x01
andwf PORTA, w ; Make w all zeros except for w,bit0 =
; PORTA<0>.
xorwf BIT, w ; TEMP,bit0 = w,bit0 XOR bit,bit0 = 1

```

Bibliography

- [1] Thomas Guthrie Zimmerman. Personal area networks (PAN): Near-field intra-body communication. Master's thesis, MIT, MIT Media Lab, 20 Ames Street, Cambridge, MA 02139, Sep 1995.
- [2] Thomas G. Zimmerman. Personal area networks: Near-field intrabody communication. *IBM Systems Journal*, 35(3):609–617, 1996.
- [3] E. Rehmi Post, Matthew Reynolds, Matthew Gray, Joe Paradiso, and Neil Gershenfeld. Intra-body buses for power and data. *Proceedings of the First Annual Symposium on Wearable Computing*, October 1997. To be published.
- [4] Matthew Gray. Physical limits of intrabody signalling. Bachelor's thesis, MIT, MIT Media Lab, 20 Ames Street, Cambridge, MA 02139, May 1997.
- [5] Richard Ribon Fletcher. A low-cost electromagnetic tagging technology for wireless identification, sensing, and tracking of objects. Master's thesis, MIT, MIT Media Lab, 20 Ames Street, Cambridge, MA 02139, Feb 1997.
- [6] Em Microelectronic-Marin SA: 1996 integrated circuits. Databook, Em Microelectronic-Marin SA, CH -2074 Marin, Rue de Sors 3, (+41) 32-755 51 11, Mar 1996. <http://www.emmarin.ch/>.
- [7] Paul Horowitz and Winfield Hill. *The Art of Electronics*. Cambridge University Press, second edition, 1989.
- [8] Federal Communications Commission. *Guidelines for Evaluating the Environmental Effects of Radiofrequency Radiation*, April 1993. Notice of Proposed Rule Making (released April 8, 1993) OET Bulletin No. 65/ET Docket No. 93-62/FCC 93-142; <http://www.fcc.gov/oet/info/documents/bulletins>.
- [9] National Research Council Committee on the Possible Effects of Electromagnetic Fields on Biologic Systems. *Possible Health Effects of Exposure to Residential Electric and Magnetic Fields*. National Research Council, 1997.